

2.3 Mounting/Dimension Drawing

Information is for standard design units only. Customers should review specific diagrams for custom units.

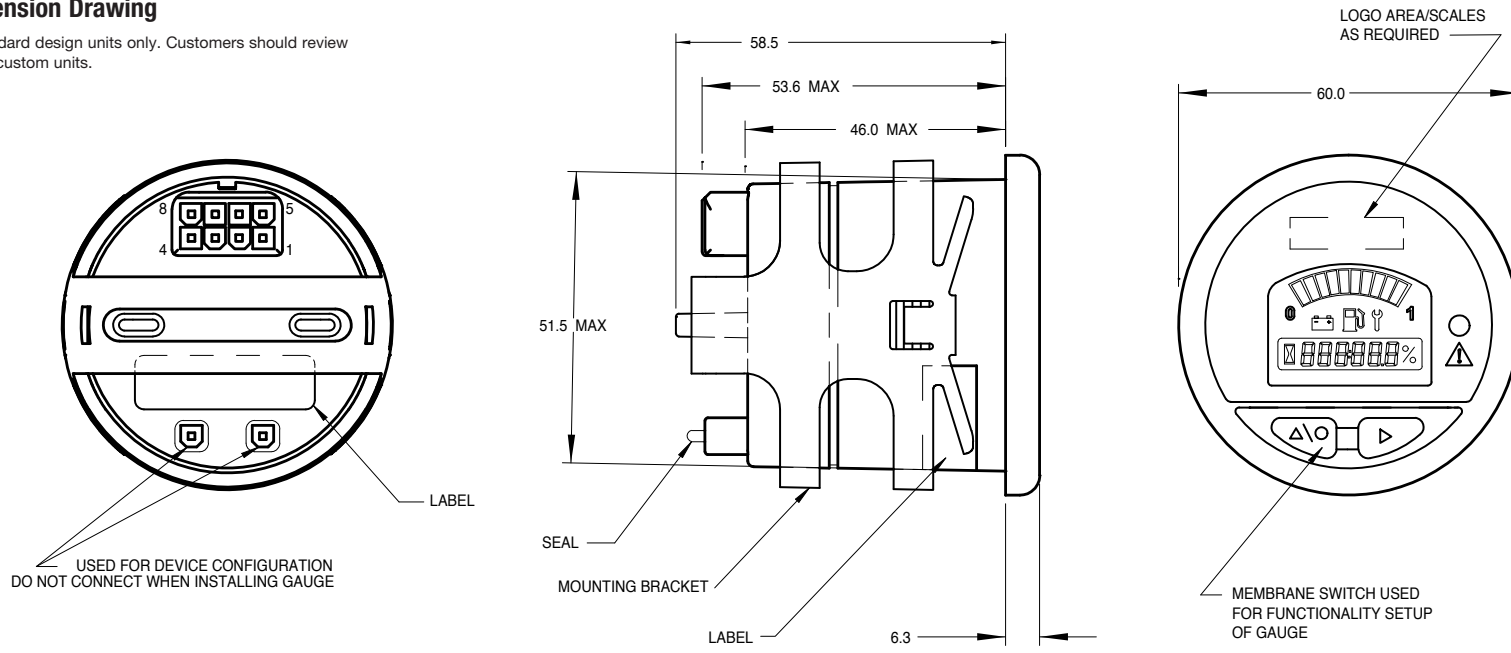

NOTES:

- 1.0 Mating Connector: 8-pin Molex P/N 39-01-2085 with UL-Rating 94V-0, pins P/N 39-00-0039 for #18-24 AWG
- 2.0 52mm meters are provided in a standard round package for mounting in a 52mm DIA dash panel hole. See detail for panel cutout with key.
- 3.0 Material: Case- Polycarbonate; Lens- clear Polymethylmethacrylat (pmma); Cover, Overlay & Mounting Bracket- Polycarbonate.
- 4.0 This unit is designed for a mounting panel thickness of 0.8mm - 6.4mm.
- 5.0 Environmental protection: Front- IP-65; Rear- IP-40.
- 6.0 Weight: 0.095 kg max, including mounting bracket.

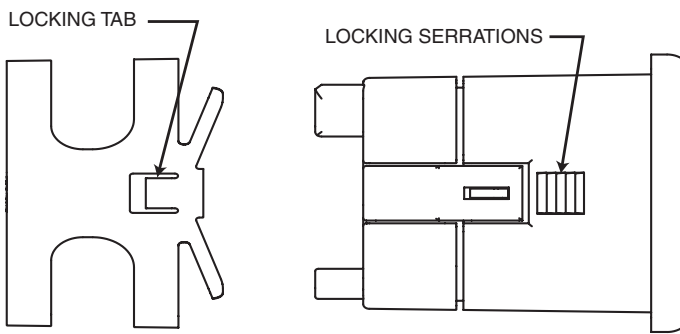

LOCKING TAB MUST ALIGN WITH LOCKING SERRATIONS

2.2 Typical Wiring Diagrams

Information is for standard design units only. Customers should review specific diagrams for custom units.

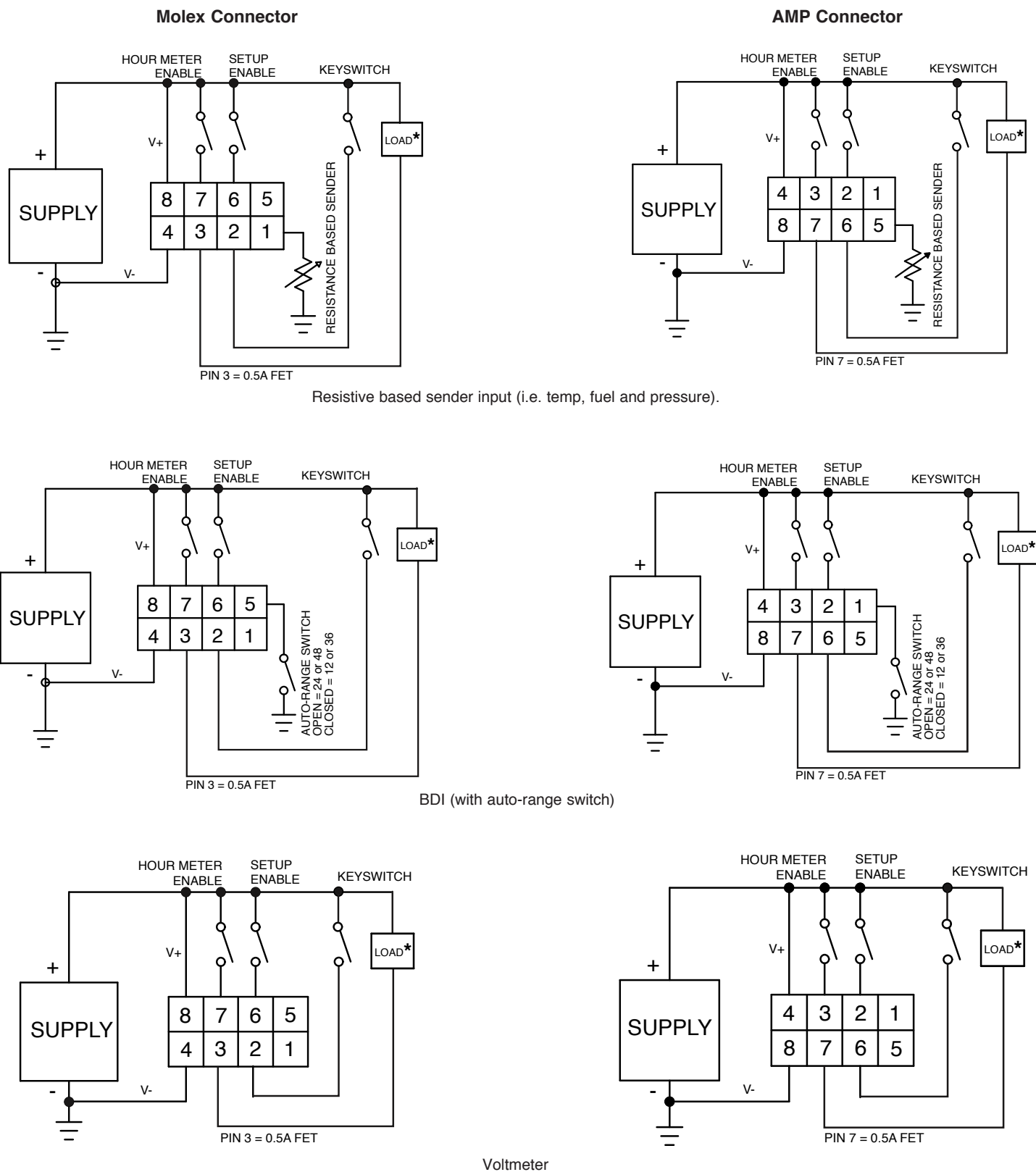

*Use of output FET driver requires installation of suppression diodes across all inductive loads.